

uni-cart

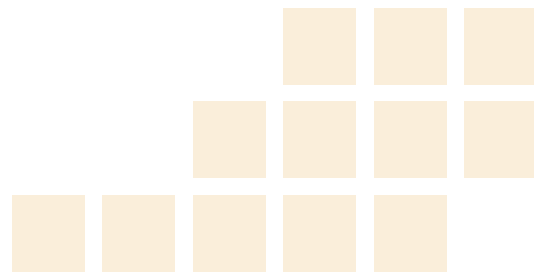

THE RIGHT CHOICE WHERE SPACE IS AT A PREMIUM

uni-cart is a compact and safe equipment cart with a loading capacity of up to 65 kg / 143 lbs. With its 4 or 5-foot-base frames and lockable wheels this trolley is particularly manoeuvrable and ideal where space is limited. The single-column aluminium extrusion is used to ensure careful storage of the cables and sockets. Also, various medical accessories, drawers, shelves, baskets and infusion stands can be easily fixed on the vertical extrusion every 32 mm.

Different colour variations can be incorporated into your medical device and options to include your corporate identity can be used to contribute to the uniform appearance of your system.

Functionality, numerous expansion options and an ideal price-performance are just some of the attractive characteristics of the **uni-cart**.

uni-cart

uni-cart

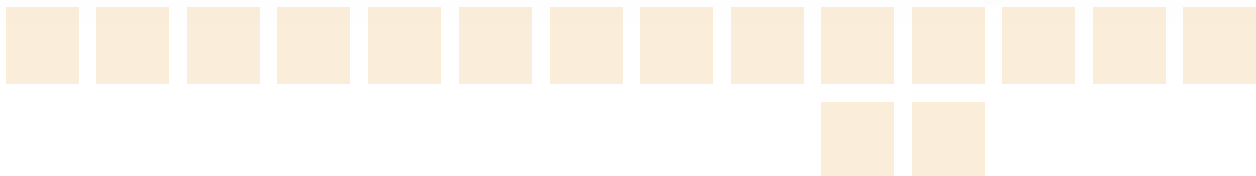

THE RIGHT CHOICE WHERE SPACE IS AT A PREMIUM

uni-cart



uni-cart masters the challenge of restricted space and difficult conditions. Optimum integration of small medical instruments enables the single-column cart to deliver the solution for flexible applications and fast mobile deployment. **uni-cart** offers lots of convenience with cabling routed in the support column. The stabilisers with individual adaptation of length offer a high level of stability.

This compact miracle in space can be used in a wide range of medical applications like physiotherapy, ultrasound diagnostics, ECG, anaesthesia and endoscopy.



uni-cart Application for stress test ECG



uni-cart Application for flexible endoscopy



uni-cart Mobile workstation



uni-cart Multiple measurement station (resting ECG / lung function)

uni-cart – THE HIGHLIGHTS AT A GLANCE



Durability and safety

- High-quality materials, such as galvanised and powder-coated steel sheets and aluminium extrusions offer reliability and security as well as ensure lasting maintenance-free operation.

Modularity

- The 32/64 mm fixing grid allows for almost limitless combinations of components and accessories.
- Accessories can be attached to the front and back of the support column.

Ergonomics and Design

- Different installation heights and optional height adjustment together allow for a natural posture during the operational use of the equipment.
- Ergonomic handles allow for effortless manoeuvrability of the loaded equipment cart.
- Lightweight construction and sleek design ensure perfect integration in the medical work environment.
- Handles and corners can have coloured decorative trims and incorporate the customer's Corporate Identity (CI).

Hygiene

- Powder-coated surfaces and plastic covers are ideal for making cleaning easy.
- The hygiene of all ITD products is validated with the certificate of the German Society for Hospital Hygiene (DGKH).

Safe power supply

- International socket outlets and cables can be added in the support columns.
- Cover strips protect the cable against unauthorised access and dust.
- The integrated tension reliever in the basic frame unit safeguards against a sudden failure of the connecting cable.

Flexibility

- 4-foot base frame: with variable stabiliser lengths and positions for optimum stability within a small space.
- 5-foot base frame: ideal for central loads.
- Lockable twin castors ensure the greatest comfort while mobile as well as secure fixture when in operational use.

MODULARITY FOR NUMEROUS CONFIGURATION OPTIONS

The modular structure is the defining feature of the **uni-cart** mobile single-column equipment cart and the entire ITD product range, which allows all support systems to be configured, customised, upgraded or easily modified for special functions and application areas using the extensive standard range. This capability allows users to react fast and consistently to any changes or new customer requirements. The T-slots on the support column ensure easy assembly of the components. The display presented alongside shows a small selection of accessories for the **uni-cart** equipment carts.



Endoscop holders or **IV poles** can be mounted in the support column or on the shelf.



Cabling to equipment is routed in the support column.



An **optional handle** can be attached to the equipment cart to improve its manoeuvrability. Moreover, the handle is decorative.





Shelves and drawers are available in different versions. The colour of corners and handles can be matched to instrumentation or CI livery.



Monitors of different sizes weighing up to 14 kg / 30.8 lbs overall can be installed by attaching various monitor holders.

ORDER CONFIGURATIONS

uni-cart



uni-cart basic version

Item number: RS.4801.XXX ¹⁾

Equipment cart, 21 U (total height: 820 mm), fitted with:

- 1 basic frame with 4 lockable twin castors Ø 75 mm
- 1 block of drawers with handle (front)
- 1 cover strip
- 1 integrated cable strain relief

uni-cart basic version

Item number: RS.4111.XXX ¹⁾

Equipment cart, 30 U (total height: 1145 mm), fitted with:

- 1 basic frame with 4 lockable twin castors Ø 100 mm
- 1 block of drawers with handle (front)
- 1 shelf
- 1 socket strip earthed, Schuko, 3-way, with on/off switch
- 1 cover strip
- 1 integrated cable strain relief

Installation height: 21 U (672 mm)
Load capacity: 65 kg / 143 lbs
Finish: RAL 7035 light grey powder-coated
Decorative trims: corners and handle see ¹⁾
Scope of delivery: assembled

Installation height: 30 U (960 mm)
Load capacity: 65 kg / 143 lbs
Finish: RAL 7035 light grey powder-coated
Decorative trims: corners and handle see ¹⁾
Scope of delivery: assembled

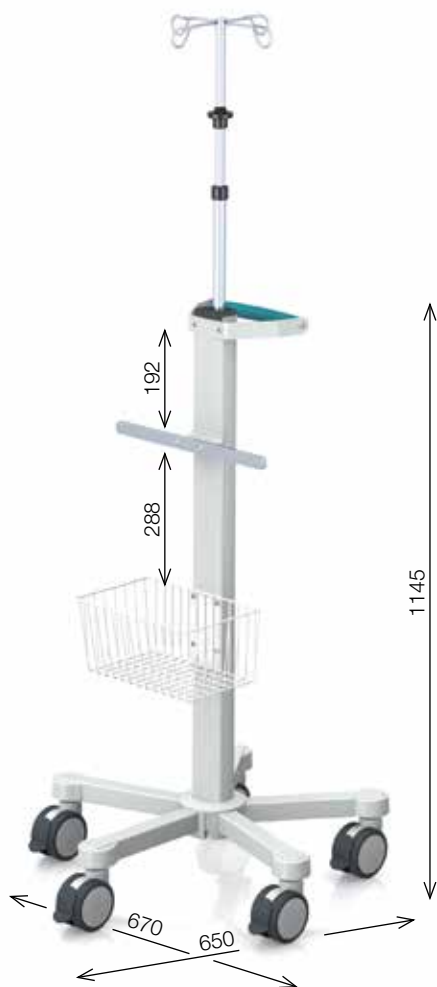

uni-cart with IV pole

Item number: RS.5800.XXX ¹⁾

Equipment cart, 30 U (total height: 1145 mm), fitted with:

- 1 basic frame with 5 lockable twin castors Ø 100 mm
- 1 IV pole
- 1 standard runner 390 mm x 10 mm x 25 mm (L x D x H)
- 1 storage basket, front
- 1 push handle, back
- 1 cover strip
- 1 integrated cable strain relief

Installation height: 30 U (960 mm)
Load capacity: 50 kg / 110 lbs
Finish: RAL 7035 light grey powder-coated
Decorative trims: handle see ¹⁾
Scope of delivery: assembled

BASIC FRAME WITH 4 STABILISERS uni-cart

Basic frame for uni-cart with 4 stabilisers

The **uni-cart** basic frame with 4 stabilisers provides high strength and stability particularly with expansive system modules such as drawers and shelves. The length of the stabiliser can be adapted to meet individual needs, so there is no risk of tipping and a high level of rigidity is ensured. The high-quality aluminium extrusion ensures safe and neat storage of cables and plugs, the integrated tension reliever protects against unauthorised disconnection of the device. Four lockable twin castors ensure high comfort while in motion and secure operational fixture.

uni-cart

Load capacity: 65 kg / 143 lbs
Material: steel / aluminium / plastic
Finish: RAL 7035 light grey powder-coated
Scope of delivery: 1 basic frame, partly assembled

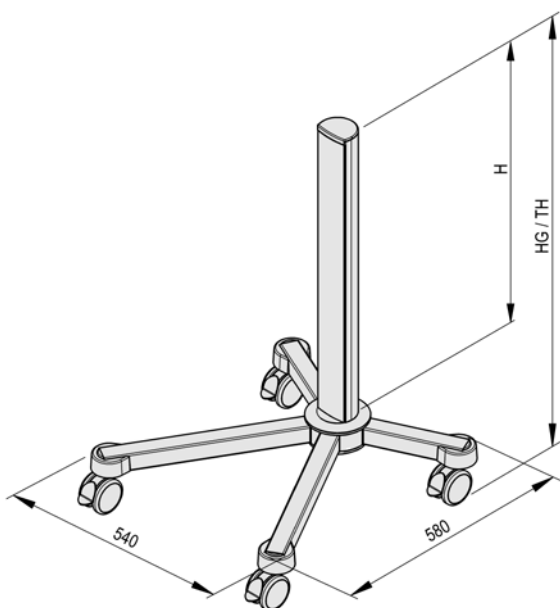

Installation height H	Total height TH	Castors Ø	Item number
21 U (672 mm)	820 mm	75 mm	RS.4008.991
30 U (960 mm)	1145 mm	100 mm	RS.4011.991
35 U ¹⁾ (1120 mm)	1305 mm	100 mm	RS.4027.991
Counterweight set for 4 stabilisers (is integrated in the stabilisers at the factory)			RS.0344.999

Castor conversion kit for uni-cart with 4 stabilisers

For further requirements – as conversion kit instead of the specified standard design – the following castors are offered:

Scope of delivery: 1 castor conversion kit, 4 castors, each with wheel lock. Factory assembly only

Castor conversion kit	Instead of standard	Item number
Ø 100 mm	Ø 75 mm	ZV.9920.999
Ø 100 mm, conductive	Ø 75 mm	ZV.9921.999
Ø 100 mm, conductive	Ø 100 mm	ZV.9922.999
Wall protector		ZV.9964.999

BASIC FRAME WITH 5 STABILISERS uni-cart

Basic frame for uni-cart with 5 stabilisers

The **uni-cart** basic frame with 5 stabilisers is particularly suitable for central loads, such as when attaching a monitor holder, an infusion holder or a gas bottle holder. The stabiliser can be adjusted in length to suit individual needs, therefore offering high stability and flexibility. The frame features high torsional rigidity within limited available space. The high-quality aluminium extrusion ensures safe and neat storage of cables and plugs and protection against unauthorised disconnection of the device through the integrated tension reliever. Five lockable twin castors ensure high comfort while in motion and secure operational fixture.

Load capacity: 50 kg / 110 lbs
Material: steel / aluminium / plastic
Finish: RAL 7035 light grey powder-coated
Scope of delivery: 1 basic frame, partly assembled

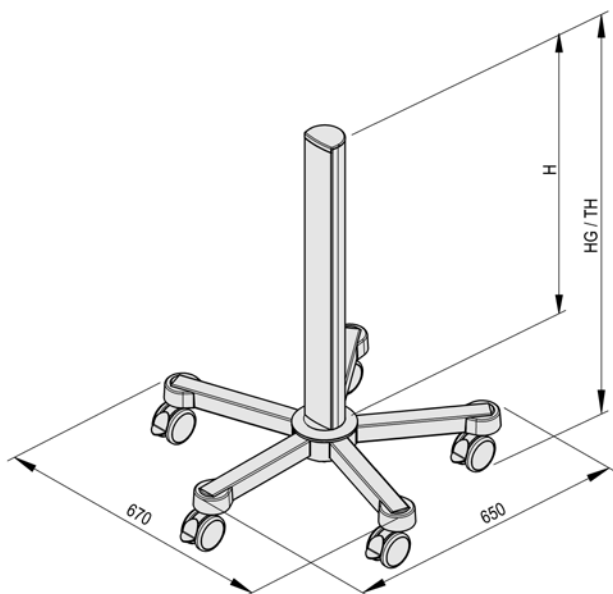

Installation height H	Total height TH	Castors Ø	Item number
21 U (672 mm)	820 mm	75 mm	RS.5008.991
30 U (960 mm)	1145 mm	100 mm	RS.5011.991
35 U ¹⁾ (1120 mm)	1305 mm	100 mm	RS.5024.991
Counterweight set for 5 stabilisers (is integrated in the stabilisers at the factory)			RS.0349.999

Castor conversion kit for uni-cart with 5 stabilisers

For further requirements – as conversion kit instead of the specified standard design – the following castors are offered:

Scope of delivery: 1 castor conversion kit, 5 castors, each with wheel lock. Factory assembly only

Castor conversion kit	Instead of standard	Item number
Ø 100 mm	Ø 75 mm	ZV.9926.999
Ø 100 mm, conductive	Ø 75 mm	ZV.9927.999
Ø 100 mm, conductive	Ø 100 mm	ZV.9929.999
Wall protector		ZV.9995.999

BASIC FRAME WITH MECHANICAL HEIGHT ADJUSTMENT uni-cart

Basic frame uni-cart with mechanical height adjustment

By means of a height adjustment mechanism, your workplace can be operated either sitting or standing. The height adjustment is mounted at a height of 35 U at the front of the vertical extrusion of the **uni-cart** basic frame. When lifting loads, the mechanical height adjustment is helped by a gas spring. Components and accessories can be mounted at a height of 12 U with a grid distance of 32/64 mm. The adjustment range is 300 mm and can be loaded with a weight of 3 to 10 kg / 6.6 - 22 lbs or from 10 up to 16 kg / 22 - 35.2 lbs. Four lockable twin castors (Ø 100 mm) ensure high comfort while in motion and secure operational fixture.

In the basic frame **uni-cart** with mechanical height adjustment the counterweight set is included.

- Total height:** 1306 mm when with castors Ø 100 mm
- Load capacity:** 65 kg / 143 lbs
- Material:** steel / aluminium / plastic
- Finish:** RAL 7035 light grey powder-coated, **support column:** anodised
- Scope of delivery:** 1 basic frame, partly assembled

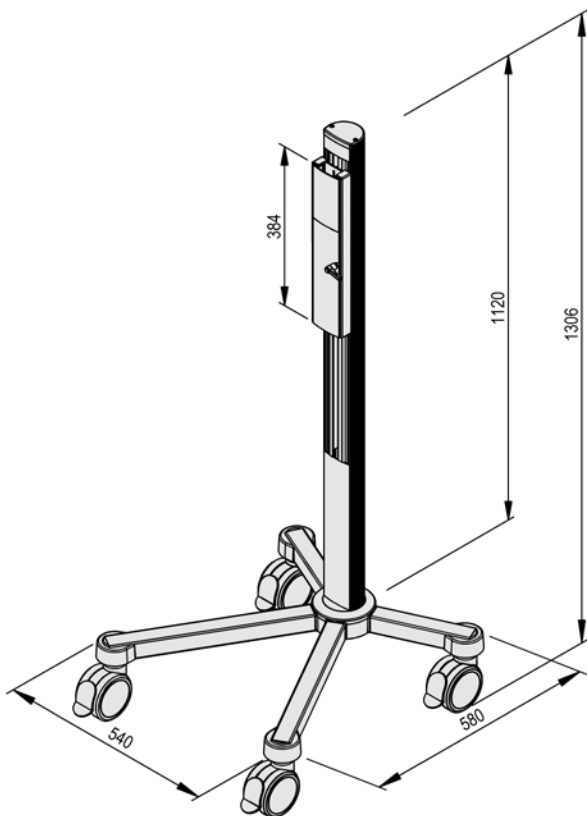

Designation	Load capacity of height adjustment	Item number
Basic frame with mechanical height adjustment	3-10 kg / 6.6-22 lbs	RS.4033.991
Basic frame with mechanical height adjustment	10-16 kg / 22-35.2 lbs	RS.4034.991

BASIC FRAME WITH ELECTRIC HEIGHT ADJUSTMENT uni-cart

Basic frame uni-cart with electric height adjustment

By means of a height adjustment mechanism, your workplace can be operated either sitting or standing. The height adjustment is mounted at a height of 35 U at the front of the vertical extrusion of the basic frame **uni-cart**. For linear drive, the electric height adjustment helps raise and lower the load. This is operated via cable-connected remote control. Components and accessories can be mounted at a height of 12 U on the slide in a grid of 32/64 mm. The adjustment range is 300 mm. The height adjustment can deal with a load weighing up to 20 kg / 44 lbs. The linear actuator of the height adjustment can be operated at 110V or 230V. Four lockable twin castors (Ø 100 mm) ensure high comfort while in motion and secure operational fixture.

In the basic frame **uni-cart** with electric height adjustment the counterweight set is included.

- Total height:** 1306 mm when with castors Ø 100 mm
- Load capacity:** 65 kg / 143 lbs
- Material:** steel / aluminium / plastic
- Finish:** RAL 7035 light grey powder-coated
- Scope of delivery:** 1 basic frame, partly assembled

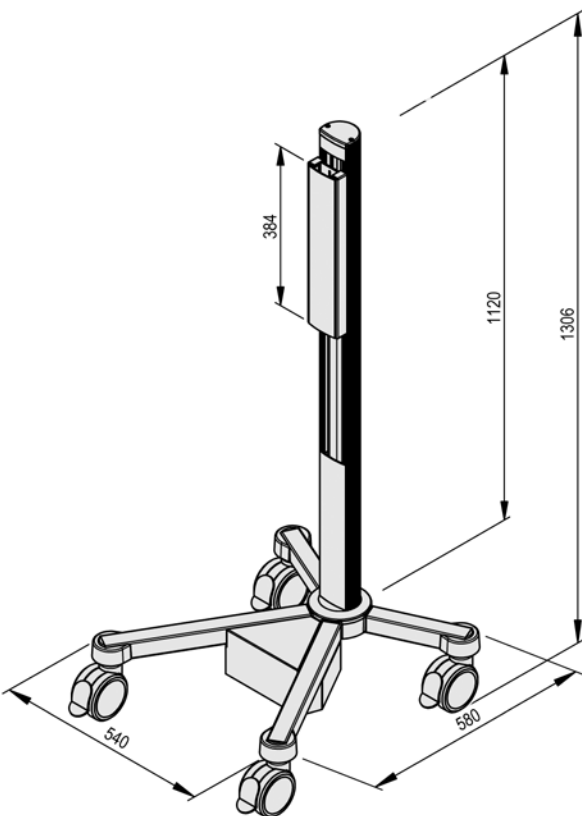

uni-cart

Designation	Load capacity of height adjustment	Input voltage	Item number
Basic frame with electric height adjustment	0-20 kg / 0-44 lbs	110 V and 50 / 60 Hz	RS.4035.991
Basic frame with electric height adjustment	0-20 kg / 0-44 lbs	230 V and 50 / 60 Hz	RS.4036.991

ISOLATING TRANSFORMER uni-cart

Isolating transformer for uni-cart with 4 stabilisers

The isolating transformer is used to reduce the dangers for patients and professionals posed by leakage by providing insulation to the network. Single-fault protection and potential-free voltage supply is guaranteed by the use of the isolating transformer. This allows a constant power supply for electro-medical equipment and a safe patient environment. The isolation transformer, in a protective conductor with a metal housing, is mounted between the two front stabilisers and has the following features:

Installation height:	3 U (96 mm) + 2 U (64 mm)
Power:	660 VA
Input / Output voltage:	115 V / 115 V or 230 V / 230 V, 50 Hz / 60 Hz – switchable
Power input:	IEC 320 EURO input for use of country-specific power cables
Design:	annular core transformer
Conditionally short-circuit proof:	in conformity with IEC 742 and IEC 601-1
Inrush current limitation:	electronically regulated to approx. 15 A
Safety class:	1
Insulation voltage:	4 KV
Fuse protection:	primary 2-phase
Material of enclosure:	steel
Finish:	RAL 7035 light grey powder-coated
Installation:	between two front stabilisers
Scope of delivery:	1 isolating transformer with base shelf, on/off Switch (on the right-hand side of the enclosure), 1 connection cable earthed Schuko 5 m, 3 EURO cable for connecting to the units and 1 panel with 4x equipotential bonding plugs mounted at the front of the column. Factory assembly only



Designation	Power	Item number
Isolating transformer	660 VA	ZV.9412.999

SOCKET STRIPS uni-cart

Socket strip Schuko, 3-way, with switch, connection cable and earthing contact for uni-cart

Ratings: 16 A / 250 VAC
Installation: in the support column
Scope of delivery: 1 socket strip Schuko, including cover strip and mounting hardware



Designation	Connection cable	Standard	Item number
Socket strip Schuko, 3-way, with switch, connection cable and earthing contact	5 m	DIN VDE 0620-1	ZV.9844.991

uni-cart

Socket strip British Standard, 3-way, with switch, connection cable and earthing contact for uni-cart

Ratings: 13 A / 250 VAC
Installation: in the support column
Scope of delivery: 1 socket strip British Standard, including cover strip and mounting hardware

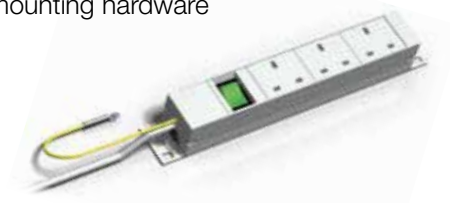

Designation	Connection cable	Standard	Item number
Socket strip British Standard, 3-way, with switch, connection cable and earthing contact	5 m	BS 1363	ZV.9758.991

Socket strip Swiss Standard, 3-way, with switch, connection cable and earthing contact for uni-cart

Ratings: 16 A / 250 VAC
Installation: in the support column
Scope of delivery: 1 socket strip Swiss Standard, including cover strip and mounting hardware

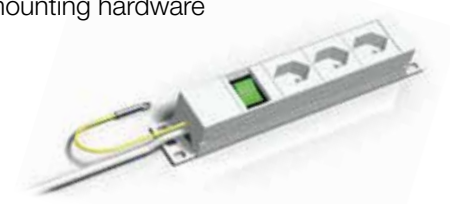

Designation	Connection cable	Standard	Item number
Socket strip Swiss Standard, 3-way, with switch, connection cable and earthing contact	5 m	SEV 1011	ZV.9848.991

Plug removal barriers are available in Chapter Accessories.

SHELVES uni-cart

Shelves for uni-cart

The shelves for the **uni-cart** are characterised by being spacious, with raised edges and rounded decorative corners. The low installation height saves space and creates valuable space for other system components. The shelves are available with various features such as handles or a mousepad. As standard, the integrated mousepad is fitted to extend to the right, but can on request be fitted to extend to the left.

uni-cart

- Installation height:** 3 U (96 mm)
- Dimensions:** 400 mm x 360 mm (W x D)
- Usable area:** 356 mm x 316 mm (W x D)
- Load capacity:** 10 kg / 22 lbs distributed load
- Material:** steel / aluminium
- Finish:** RAL 7035 light grey powder-coated
- Decorative trims:** **corners** and **handle** see ¹⁾
- Installation:** in the front T-slots of support column
- Scope of delivery:** 1 shelf including bracket and mounting hardware, pre-assembled

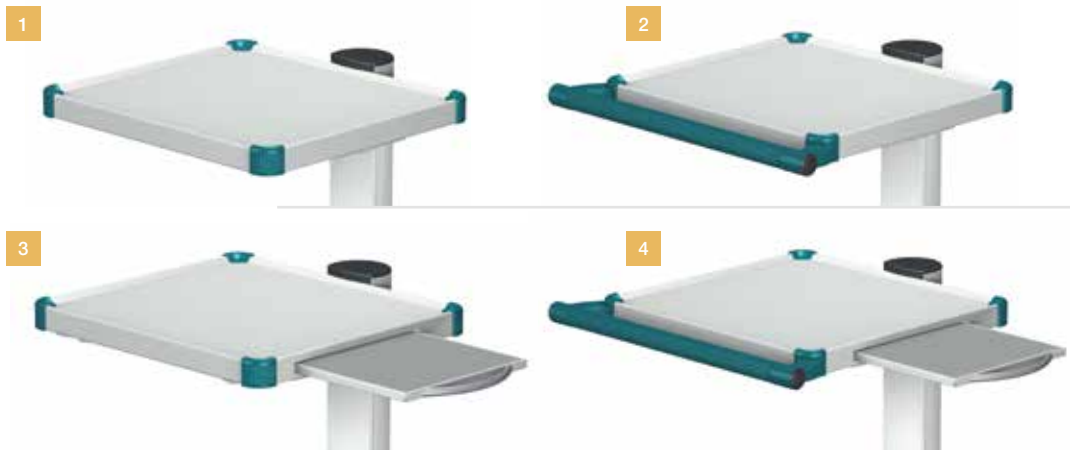

Designation	Item number
1 Shelf	RS.4360.XXX ¹⁾
2 Shelf with handle	RS.4361.XXX ¹⁾
3 Shelf with mousepad	RS.4370.XXX ¹⁾
4 Shelf with handle and mousepad	RS.4372.XXX ¹⁾

Base shelf for uni-cart

The base shelf provides a cost-effective option, e.g. for placing printers directly on the base of the equipment cart.

- Installation height:** 1 U (32 mm)
- Dimensions:** 450 mm x 400 mm (W x D)
- Usable area:** 450 mm x 400 mm (W x D)
- Load capacity:** 20 kg / 44 lbs distributed load
- Material:** steel
- Finish:** RAL 7035 light grey powder-coated
- Installation:** in the front T-slots of support column and at front stabilisers
- Scope of delivery:** 1 base shelf including mounting hardware



Designation	Item number
Base shelf	RS.0143.991

¹⁾ Decorative trims: please replace .XXX with .901 = RAL 5021 water blue, .902 = RAL 5013 cobalt blue, .903 = RAL 7035 light grey

DRAWERS uni-cart

Block of drawers for uni-cart

The **uni-cart** drawers are designed as a complete unit. They are characterised by providing a large storage space and a smooth removable inner body. All the drawers are roller-guided and are easy and comfortable to use. The drawers are available with various features such as handles or a mousepad. As standard, the integrated mousepad is fitted to extend to the right, but can on request be fitted to extend to the left.

Dimensions:	400 mm x 360 mm (W x D)
Usable area:	356 mm x 316 mm (W x D)
Interior area:	block of drawers: 310 mm x 260 mm x 75 mm (W x D x H) block of drawers high: 310 mm x 260 mm x 175 mm (W x D x H)
Load capacity:	shelf: 10 kg / 22 lbs distributed load, drawer: 3 kg / 6.6 lbs distributed load
Material:	steel / aluminium / plastic
Finish:	RAL 7035 light grey powder-coated
Decorative trims:	corners and handle see ¹⁾
Installation:	in the front T-slots of support column
Scope of delivery:	1 block of drawers including bracket and mounting hardware, pre-assembled

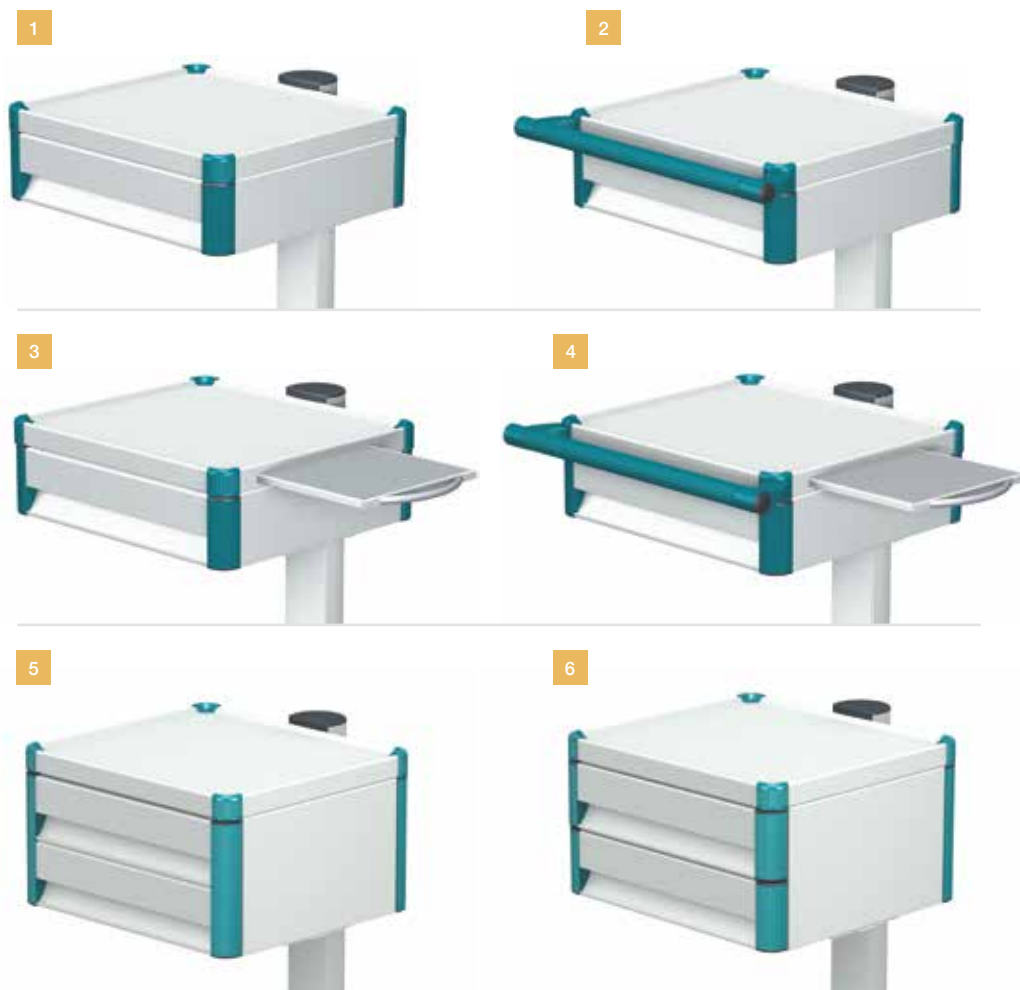

Designation	Installation height	Item number
1 Block of drawers	6 U (192 mm)	RS.4363.XXX ¹⁾
2 Block of drawers with handle	6 U (192 mm)	RS.4364.XXX ¹⁾
3 Block of drawers with mousepad	6 U (192 mm)	RS.4369.XXX ¹⁾
4 Block of drawers with handle and mousepad	6 U (192 mm)	RS.4368.XXX ¹⁾
5 Block of drawers, 1 unit, high	9 U (288 mm)	RS.4381.XXX ¹⁾
6 Block of drawers, 2 units	9 U (288 mm)	RS.4389.XXX ¹⁾

¹⁾ Decorative trims: please replace .XXX with .901 = RAL 5021 water blue, .902 = RAL 5013 cobalt blue, .903 = RAL 7035 light grey

PUSH HANDLE uni-cart

Push handle for uni-cart

The push handle can be adjusted in 32 mm steps and can be attached at individual heights along the **uni-cart** support column.

- Installation height:** 1 U (32 mm)
Material: steel / aluminium
Finish: RAL 7035 light grey powder-coated
Decorative trims: **handle** see ¹⁾
Installation: in the front T-slots of support column
Scope of delivery: 1 handle including mounting hardware



Designation







Push handle for **uni-cart**

Item number

RS.0160.XXX¹⁾

MONITOR HOLDERS uni-cart

Monitor holders for uni-cart

Installation	On the support column		At the front of the support column	
VESA 75 / 100	 <p>± 20° tilt ± 170° swivel</p>		 <p>± 20° tilt ± 20° swivel</p>	
	Monitor weight	Item number	Monitor weight	Item number
	0-14 kg / 0-30.8 lbs	RS.0408.991	0-14 kg / 0-30.8 lbs	TH.2002.991
	14-18 kg / 30.8- 39.6 lbs	RS.0409.991	14-18 kg / 30.8- 39.6 lbs	TH.2003.991
VESA 75 / 100 universal	 <p>± 15° tilt ± 170° swivel</p>		 <p>± 15° tilt ± 25° swivel</p>	
	Monitor weight	Item number	Monitor weight	Item number
	0-14 kg / 0-30.8 lbs	RS.0386.991	0-14 kg / 0-30.8 lbs	TS.6359.991
VESA 75 / 100 adjustable	 <p>± 15° tilt ± 170° swivel</p>		/	
	Monitor weight	Item number		
	0-14 kg / 0-30.8 lbs	RS.0325.991		
Universal adapter	<p>Adapter plates for universal adapter on page 149</p>  <p>± 15° tilt ± 170° swivel</p>		/	
	Monitor weight	Item number		
	0-14 kg / 0-30.8 lbs	RS.0109.800		
Table Top Mount-Adapter (Philips)	 <p>± 15° tilt ± 170° swivel</p>		/	
	Monitor weight	Item number		
	0-14 kg / 0-30.8 lbs	RS.0397.991		

Material:

steel / aluminium

Finish:

RAL 7035 light grey powder-coated, **universal adapter:** anodised

Scope of delivery:

1 monitor holder including mounting hardware and corresponding cap if necessary.

NB: Please note that the Table Top Mount adapter is supplied without a Table Top Mount!